



Santa Fe Rx



A unique dehumidifier solution that can be integrated into the living space. The **Santa Fe Rx** is a great solution for a living room, bedroom, office space, or anywhere that needs supplemental dehumidification. Its clean design blends into any home or office décor.

| | | |
|--------------------------------|---|-----------------------|
| Part Number: | 4030440 | |
| Blower: | 230 CFM @ 0.0" WG | |
| Power: | 630 watts @ 80°F and 60% RH | |
| Supply Voltage: | 115 volt – 1phase – 60 Hz | |
| Current Draw: | 5.4 amps | |
| Operating Temp.: | 60°F Min., 95°F Max. | |
| Sized for: | 2,200 Sq. Ft. - Typical | |
| Minimum Performance at: | | |
| | 80°F and 60%RH | 70°F and 60%RH |
| Water Removal: | 74 Pints/Day | 66 Pints/Day |
| Efficiency: | 5.2 Pints/kWh | 5.03 Pints/kWh |
| Energy Factor: | 2.47 L/kWh | 2.38 L/kWh |
| Air Filter: | MERV-13, Standard Pleat | |
| Size: | 16" x 20" x 2" | |
| Power Cord: | 10', 115 VAC, Ground | |
| Drain Hose: | 3/16" ID x 20', 15' Lift Capacity (Internal pump included) | |
| Drain Hose: | 5/16" OD x 20', 15' Lift Capacity (Internal pump included) | |
| Refrigerant Type: | R410A (Refer to manufacturers label for more information) | |
| Refrigerant Amount: | 1 lb., 8 oz. | |

| | Unit | With Secondary Filter Housing | Shipping |
|---------|---------|-------------------------------|----------|
| Width: | 23" | 23" | 24" |
| Height: | 37.5" | 37.5" | 46" |
| Length: | 20" | 24.75" | 26" |
| Weight: | 130 lbs | | 146 lbs |

| Optional Accessories: | |
|-----------------------|--|
| 4021475 | MERV-11 Filter (16" x 20" x 2") |
| 4027420 | MERV-11 Filters 4-Pack |
| 4027424 | MERV-11 Filters 12-Pack |
| 4037723 | MERV-13 Filter (16" x 20" x 2") |
| 4037733 | MERV-13 Filters 4-Pack |
| 4037734 | MERV-13 Filters 12-Pack |
| 4023869 | Filter Housing |
| 4022489 | MERV-14 Filter (16" x 20" x 2") (needs filter housing, 4023869 - use 2) |
| 4024145 | HEPA Filter (needs filter housing) |
| 4024528 | Bulk Carbon Granules (5 gallon bucket) |

- **Automatic condensate removal** via internal condensate pump
- Insulated cabinet and reduced fan speed ensure **quiet operation**
- Only 5.4 amps resulting in **low operating costs**
- **Large capacity** water removal of 74 pints/day
- **High efficiency** of 5.2 pints/kWh, far better than most conventional dehumidifiers
- MERV-13 Filter is standard and provides **superior air filtration**
- **Additional filtration options** include Carbon Granules and HEPA

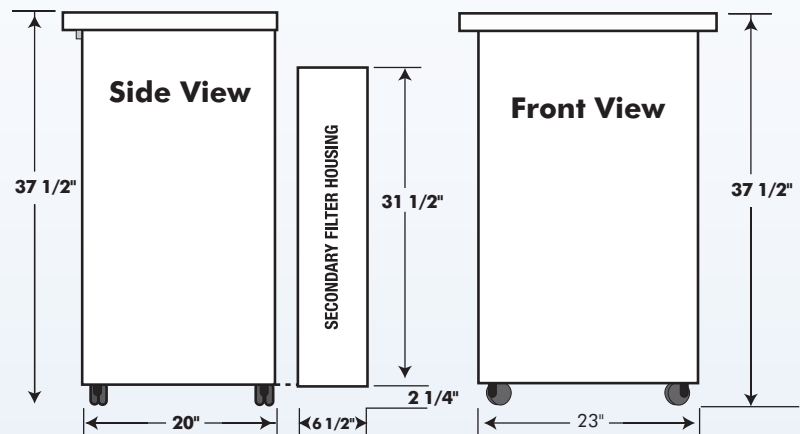
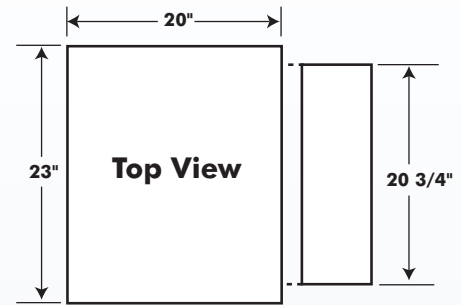

Santa Fe Rx with Secondary Filter Housing

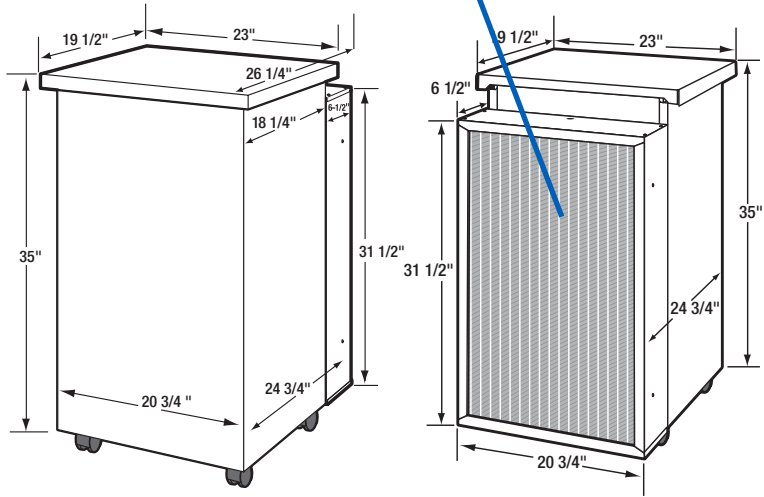

Santa Fe Rx Control Panel

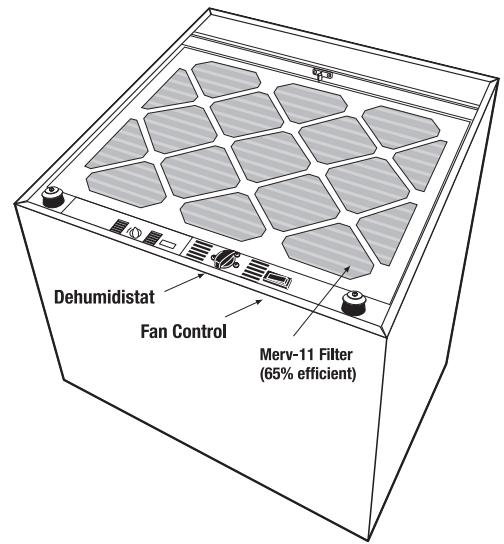

The Best in the Industry!

www.Santa-Fe-Products.com ■ 1.800.533.7533

Rev 10/16/17