

# ▶ SANTA-FE ULTRA MD33



The **Ultra MD33 In-Wall Dehumidifier\*** features a slim profile of only 5 3/4" deep, allowing it to easily fit inside 2" x 6" or through 2" x 4" interior stud walls.

The unit is the perfect solution to control moisture in multi-family applications, basements, hotels, and other spaces needing dehumidification.

## MODEL 4044610

### PERFORMANCE

Water Removal	@ 80°F and 60%RH	@ 65°F and 60%RH
	37 Pints / 4.6 Gallons	22 Pints / 2.75 Gallons
Efficiency	5.1 Pints/kWh	3.46 Pints/kWh
Energy Factor	2.4 L/kWh	1.64 L/kWh
Blower	150 CFM @ 0.0" WG	
Operating Temperature	49°F Min., 95°F Max.	
Sizing	Up to 1,200 Sq. Ft. / 12,000 Cu. Ft.	

### ELECTRICAL

Power	260 watts @ 65°F and 60%RH
Supply Voltage	120 VAC – 1 phase – 60 Hz
Current Draw	2.2 amps @ 65°F and 60%RH
Power Cord	10', 115 VAC, Ground or Hard-Wired
Circuit Requirement	15 Amps



Plug Type B

### SPECIFICATIONS

Sound Rating	46 dBA
Drain Connection	3/4" O.D.
Drain Hose	10' Condensate Hose (3/4" OD)
Refrigerant	R454B, 7.2 oz.
Unit Dimensions	14.1875"W x 30"H x 5.75"D
Unit Weight	39 lbs.

### SHIPPING

Shipping Dimensions	20"W x 37"H x 11"D
Shipping Weight	57 lbs.
Pallet Quantity	8 per pallet
UPC Number	810017961702
Shipping Options	UPS or LTL

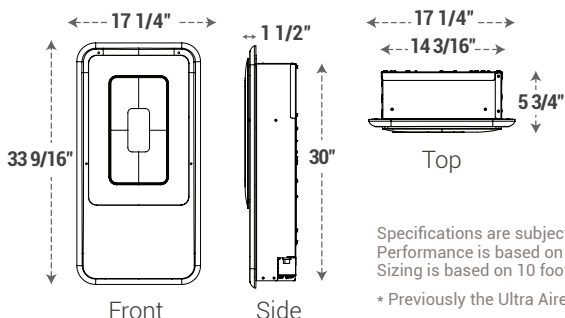

Specifications are subject to change without notice.  
Performance is based on pints / gallons per day.  
Sizing is based on 10 foot ceiling height.

\* Previously the Ultra Aire MD33.

### FEATURES

- + Designed for quiet operation
- + Washable air filter
- + Professional-grade, corrosion-resistant dual-coated coils
- + Ability to be hardwired into existing electrical or directly plugged into a 110v outlet
- + Designed to drain into a hub-drain or plumbing line
- + Internally mounted digital dehumidistat

### ACCESSORIES

- + Surface Mount Kit Part No. 4037766
- + 2x4 Wall Mount Bezel Kit Part No. 4037767
- + Rear Panel Kit Part No. 4037768



**SANTA-FE™**  
DEHUMIDIFIERS



**SANTA-FE™**  
**6-YEAR TOTAL PEACE OF MIND WARRANTY**  
5-YEAR FULL REPLACEMENT + 1-YEAR PARTS



ENGINEERED  
& ASSEMBLED  
MADISON, WI

**BUILT TO LAST. POWERED TO PROTECT.**



## DEDICATED DEHUMIDIFICATION FOR COMFORT, HEALTH AND PROPERTY PROTECTION

According to experts, controlling humidity is essential for comfort, reducing health risks, and protecting the structure and its contents. While the air conditioning will remove moisture from the air, it only does so when it is running for a significant amount of time, and never to a set relative humidity. Newer systems offer dehumidification, but in reality, they are only overcooling to try to remove more moisture, and in most cases are oversized for smaller spaces.

Indoor humidity levels can rise dramatically when outside temperatures are moderate, and the air conditioner is not running. The Santa-Fe Ultra MD33 In-Wall Dehumidifier is an ideal solution for ensuring a healthy and comfortable living space in basements, apartments, tiny homes, hotel rooms, and homes that are using ductless mini-splits for heating and cooling.

### COMFORT

Addressing comfort in a living space is very important. High humidity can cause us to feel either hot and sticky or cold and clammy, while it also contributes to musty odors.

### HEALTH

According to the Environmental Protection Agency, health problems associated with poor indoor air quality include eye irritation, allergies, headaches and respiratory problems such as asthma.

### PROPERTY PROTECTION

Maintaining proper humidity levels is one of the most important steps in protecting a living space and its contents. Excess moisture can cause musty odors, be detrimental to wood floors, furniture, artwork, electronics, and even the overall structure.

### THE SOLUTION

The Santa-Fe Ultra MD33 In-Wall Dehumidifier controls excessive moisture that contributes to poor indoor air quality, property damage, mold, comfort complaints, and reputational risk and liability. Including a dedicated in-wall dehumidifier as an integral part of the mechanical system protects the physical investment and creates a comfortable, healthier living environment.