

INSTALLATION INSTRUCTIONS



The **Santa-Fe Ultra70** is a ventilating dehumidifier that integrates with the heating and cooling system to provide the ultimate in comfort, health and property protection through:

- + Dehumidification
- + Outdoor Air Ventilation (Optional)
- + MERV-13 Air Filtration

Serial Number _____

Install Date _____

Sold By _____



SANTA-FETM
6-YEAR TOTAL PEACE OF MIND
WARRANTY
5-YEAR FULL REPLACEMENT + 1-YEAR PARTS



ENGINEERED
& ASSEMBLED
MADISON, WI

Patent: rpc-pat.com



Safety Instructions.....	3
Assembly & Registrations.....	4
Dehumidifier Set Up	5
Attaching Duct Collars.....	6
Electrical Requirements.....	7
Drain Installation.....	8
Ducting to HVAC Systems	9-15
Outdoor Air Ventilation	16-17
Controls	18-19
Air Filtration.....	20-21
Service	22-27
Warranty	28

1015 East Washington Avenue | Madison, Wisconsin 53703
1-800-334-6011
www.Santa-Fe-Products.com
© 2026 Santa-Fe Dehumidifiers



WARNING!

THIS SYMBOL MEANS IMPORTANT INSTRUCTIONS. FAILURE TO HEED THEM CAN RESULT IN SERIOUS INJURY OR DEATH.

CAUTION!

THIS SYMBOL MEANS IMPORTANT INSTRUCTIONS. FAILURE TO HEED THEM CAN RESULT IN INJURY OR MATERIAL PROPERTY DAMAGE.

Read the installation, operation and maintenance instructions carefully before installing and operating this device. Proper adherence to these instructions is essential to obtain maximum benefit from the Santa-Fe Whole House Ventilating Dehumidifier.

WARNING!

120 VOLTS MAY CAUSE SERIOUS INJURY FROM ELECTRIC SHOCK. DISCONNECT ELECTRICAL POWER BEFORE STARTING INSTALLATION OR SERVICING, AND LEAVE POWER DISCONNECTED UNTIL INSTALLATION OR SERVICE IS COMPLETED.

CAUTION!

- Always use caution and wear CUT RESISTANT gloves when handling sheet metal.
- Improper installation may cause property damage or injury. Installation, service, and maintenance must be performed by a qualified service technician.
- The dehumidifier is heavy. Handle with care and follow installation instructions.
- Never operate a unit with a damaged power cord. If the power cord is damaged, it must be replaced by the manufacturer, its service agent, or a similarly qualified person in order to avoid a hazard.
- This appliance is not intended for use by persons (including children) with reduced physical, sensory or mental capabilities, or lack of experience or knowledge, unless they have been given supervision or instruction concerning the use of the appliance by a person responsible for their safety. Children should be supervised to ensure that they do not play with the appliance.
- The device is designed to be installed indoors in a space that is protected from rain and flooding.
- Install the unit with enough space to access all sides for maintenance and service. The entire shell needs to be removed in order to do repairs.
- Avoid directing the discharge air at people. The dehumidifier should be used in the upright position.
- If used near a water source; be certain there is no chance the unit could fall into the water or get splashed and that it is plugged into a dedicated circuit and Ground Fault Circuit Interrupter (GFCI) protected outlet.
- DO NOT use the dehumidifier as a bench or table.
- Do not place the dehumidifier directly on structural building members without vibration absorbers or unwanted noise may result. Place the Santa-Fe dehumidifier on supports to raise the base of the unit.
- A drain pan with a float switch must be placed under the dehumidifier if installed above a living area or above an area where water leakage could cause damage.
- Make all electrical connections in accordance with the current edition of the NEC ANSI/NFPA 70 and any national and local codes or ordinances that may apply.
- Maintain a minimum 1ft. (.3m) clearance to avoid obstructing the air return and supply.
- Not intended for use at altitudes over 6500 ft (2000M).
- The minimum floor area of the storage room shall be 28 m2 (square meters).



**REFRIGERANT
SAFETY GROUP
A2L**

WARNING!

DO NOT USE MEANS TO ACCELERATE THE DEFROSTING PROCESS OR TO CLEAN, OTHER THAN THOSE RECOMMENDED BY THE MANUFACTURER. THE APPLIANCE SHALL BE STORED IN A ROOM WITHOUT CONTINUOUSLY OPERATING IGNITION SOURCES (FOR EXAMPLE: OPEN FLAMES, AN OPERATING GAS APPLIANCE, OR AN OPERATING ELECTRIC HEATER. DO NOT PIERCE OR BURN. BE AWARE THAT REFRIGERANTS MAY NOT CONTAIN AN ODOR.



ASSEMBLY:

1. Unpack Box.
2. Check that you have all parts:

a. Dehumidifier (1)



b. Leveling feet (4)



c. Filter - 9"x11"x1" MERV 13 (1)



d. 8" Round Duct Collars (2)



3. Register warranty at santa-fe-products.com
4. Read all remaining steps and warnings before continuing.

REGISTRATIONS



THE SANTA-FE ULTRA70 CONFORMS TO UNIFIED STANDARD UL 60335-2-40 AND CSA STANDARD C22.2.60335-2-40.

Brand Name	Individual Model Number	Basic Model Number	Rating Conditions	Integrated Energy Factor (L/kWh)	Capacity (Pint/Day)
Santa-Fe Ultra70	4044100	70.1-W	73F/60%	2.04	52.45

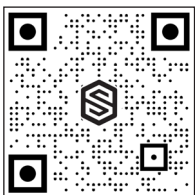

Scan to Register Product



Location Considerations

- Allow sufficient clearance to handle the unit's overall dimensions as well as the necessary return and supply ductwork to the unit.
- Allow sufficient clearance for filter removal and to prevent airflow obstruction.
- Electrical service access will require the removal of the outside shell. Allow sufficient clearance around the unit.
- Locate the dehumidifier in an area where the unit's 9 ft. cord can easily reach electrical outlet.
- Locate the dehumidifier in an area where field wiring the control (low voltage) to the unit will be possible.
- A back draft damper is required in the supply duct of the dehumidifier, especially when connecting to the supply ducting system. The backdraft damper prevents supply air from counter flowing through the dehumidifier when it is not operating. The dehumidifier's location should be chosen to allow installation of this accessory if necessary.
- The dehumidifier may be suspended with the hang kit or a suitable alternative from structural members, ensuring the assembly supports the dehumidifier's base in its entirety. Do not hang the dehumidifier from its' cabinet.
- Allow for proper drainage and routing of needed drain pipes.
- Place the dehumidifier on supports that raise the base of the unit 6" above the secondary drain pan so a P-trap can be installed.
- The dehumidifier should not hang from sides or ends.
- If installing on ground, use included plugs to cover hanging locations on top of the machine.
- If hanging machine in air, use included plugs to cover holes in base pan for leveling feet.
- Keep any required ventilation openings clear of obstruction.
- Ducts connected to the dehumidifier shall not contain a POTENTIAL IGNITION SOURCE.
- Supply and return air shall be directly ducted to the space. Open areas such as false ceilings shall not be used as a return air duct.

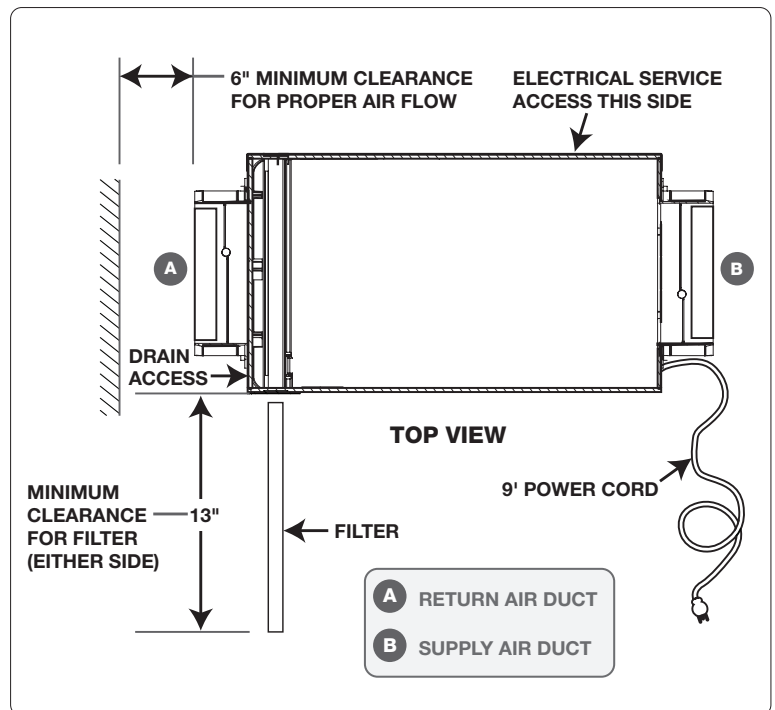

Unventilated Areas

- Unventilated areas where the dehumidifier is installed or stored need to be so constructed that should any refrigerant leak, it will not stagnate so as to create a fire or explosion hazard.
- The dehumidifier shall not be stored or ducted into one or multiple rooms with continuously operating open flames (for example an operating gas appliance) or other POTENTIAL IGNITION SOURCES (for example an operating electric heater, hot surfaces). A flame-producing device may be installed in the same space if the device is provided with an effective flame arrest.



1. Outdoor Air Ventilation Duct

Outdoor air ventilation is optional. If setting up the unit to provide outdoor air ventilation, see page 10.

2. Return Air Inlet

An 8" diameter duct collar is attached to the unit.

3. Supply Air Outlet

An 8" diameter duct collar is attached to the unit. The back panel of the dehumidifier can be rotated to allow for horizontal flow through or vertical flow through of the supply air.

a. Horizontal Flow Through

The unit ships configured for a horizontal flow through.

b. Vertical Flow Through

Remove the exhaust panel using a T20 torx bit. Rotate the panel so the exhaust collar is located on the top of the unit. Align screw holes and snap the panel onto the base. Secure the supply panel to the base by replacing the six screws.

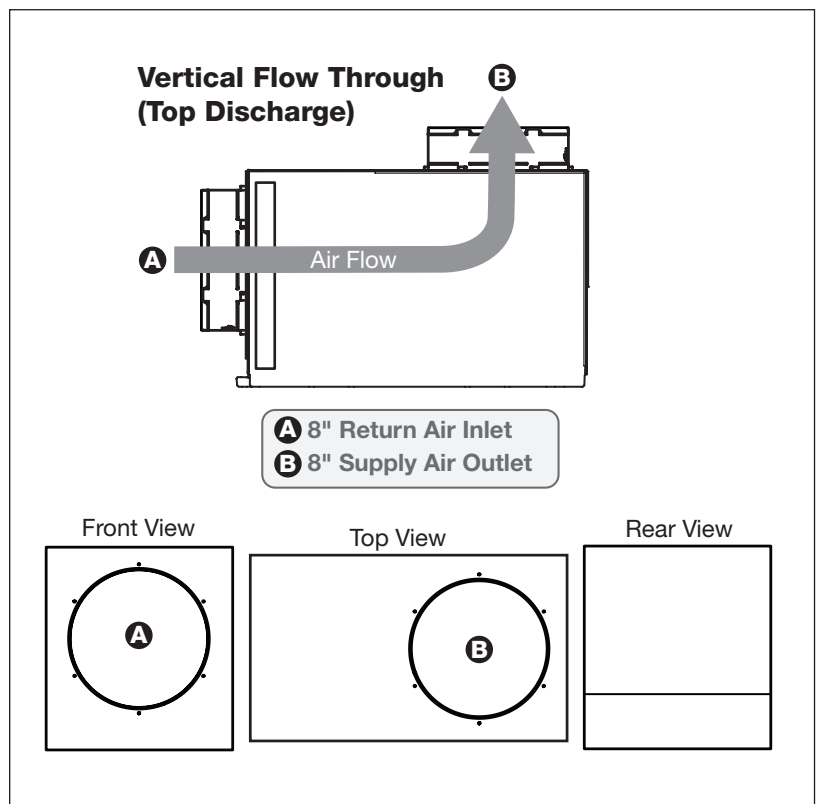
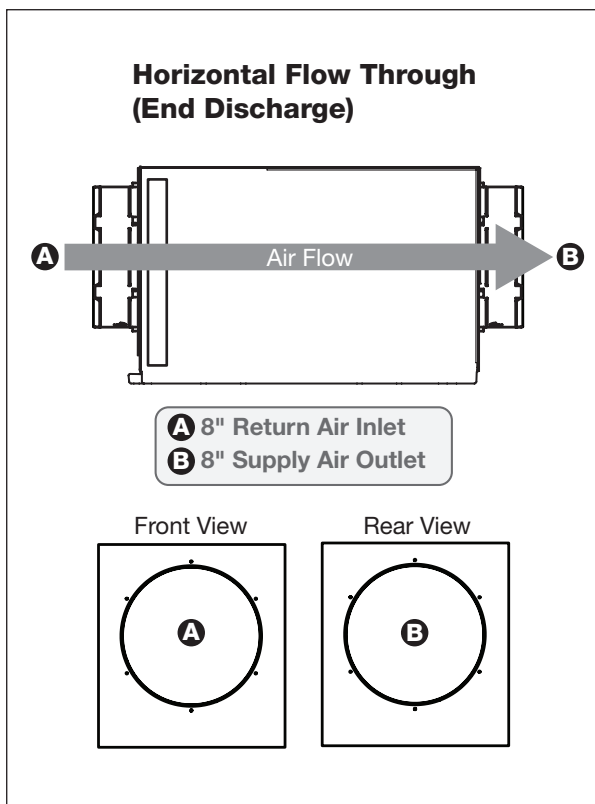

ELECTRICAL REQUIREMENTS



The Santa-Fe Ultra70 plugs into a common grounded 115VAC outlet and draws 5.4 Amps. Locate the dehumidifier in an area where the unit's 9 ft. cord can easily reach a 115 VAC electrical outlet with a minimum of 15 Amp circuit capacity. If used in an area that may become wet, a GFCI protected circuit is recommended. Consult local electrical codes for any further information.

Santa-Fe offers a variety of control devices for use with the Santa-Fe Ultra70. The controls are to be located remotely from the dehumidifier and placed in the space to be conditioned. Low voltage (24 Volt) controls can be used with the Santa-Fe Ultra70 and MUST be connected with low voltage (18-22 gauge) thermostat wire.

⚠️ WARNING!

THE REMOTE CONTROLS OF THE SANTA-FE ULTRA70 ARE POWERED BY A LOW VOLTAGE CIRCUIT (24VAC) AND MUST NEVER CONTACT OR BE CONNECTED TO A HIGH VOLTAGE CIRCUIT.

⚠️ CAUTION!

DO NOT ALLOW THE 24V TERMINAL TO CONTACT THE COM TERMINALS ON THE SANTA-FE ULTRA70 OR DAMAGE TO THE TRANSFORMER WILL RESULT.

⚠️ CAUTION!

SOME OF THE SCREWS TERMINALS ON THE SANTA-FE ULTRA70 MAY NOT BE USED WITH CERTAIN CONTROLS AND SHOULD BE LEFT UNCONNECTED.

Electrical Precautions

- Do not install the control where it may not accurately sense the relative humidity such as near HVAC supply registers, near exterior doors, on an outside wall, near a window, or near a water source.
- The screw terminals on the Santa-Fe Ultra70 and the control are labeled to prevent confusion.
- Be sure to consult the electrical schematic in the CONTROLS Section (page 12) of this manual or inside the access panel of the Santa-Fe Ultra70 before making control connections.

Wiring Schematic

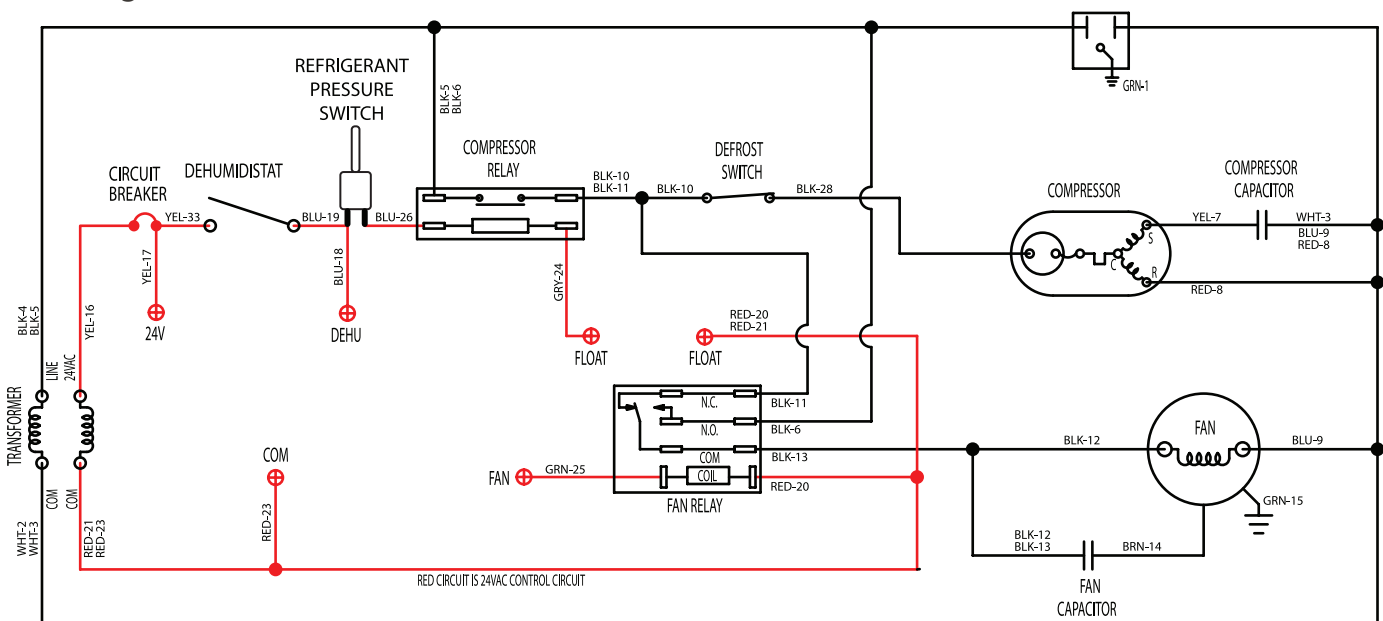

4043985 REV A



The Santa-Fe Ultra70 generates condensate.

Place a secondary drain pan with a float switch under the dehumidifier if it is suspended above a finished area or in an area where water leakage could cause damage.

A drain trap is required for the dehumidifier to run properly (see diagram below). Install a 3/4" threaded male NPT adapter to the drain pan. Install a drain pipe assembly utilizing 3/4" PVC pipe to transport the condensate to a drain. Pitch of drain should be 1" per 10'.

An optional condensate pump kit is available for use with the Santa-Fe Ultra70 and may be installed if lift is required to dispose of condensate. Condensate is automatically pumped to a remote location when the water level in the pump's reservoir rises to close the float switch.

The pump also contains a safety float switch. The white leads from this switch extend from beneath the pump cover. This switch should be installed in series with the field wire that connects to the common lead from the Santa-Fe Ultra70 to the control panel. If the pump fails, this switch opens the common control circuit and stops water production before the reservoir overflows. Contact a qualified electrician to install the safety float switch to the Santa-Fe Ultra70 dehumidifier.

Drain Installation

Dehumidifiers commonly use a negative air pressure drain pan. This causes air to flow backwards thru the drain system which can cause water to pool inside the dehumidifier and leak. A drain trap prevents this issue by trapping water in the pipe to stop air from flowing backwards.

Please see the trap diagram below. This assembly can be made with common 3/4" PVC pipe fittings. The pipe measurements and placement of the cap and vent are critical to the function of the trap. Once trap is assembled, be sure to fill with water.

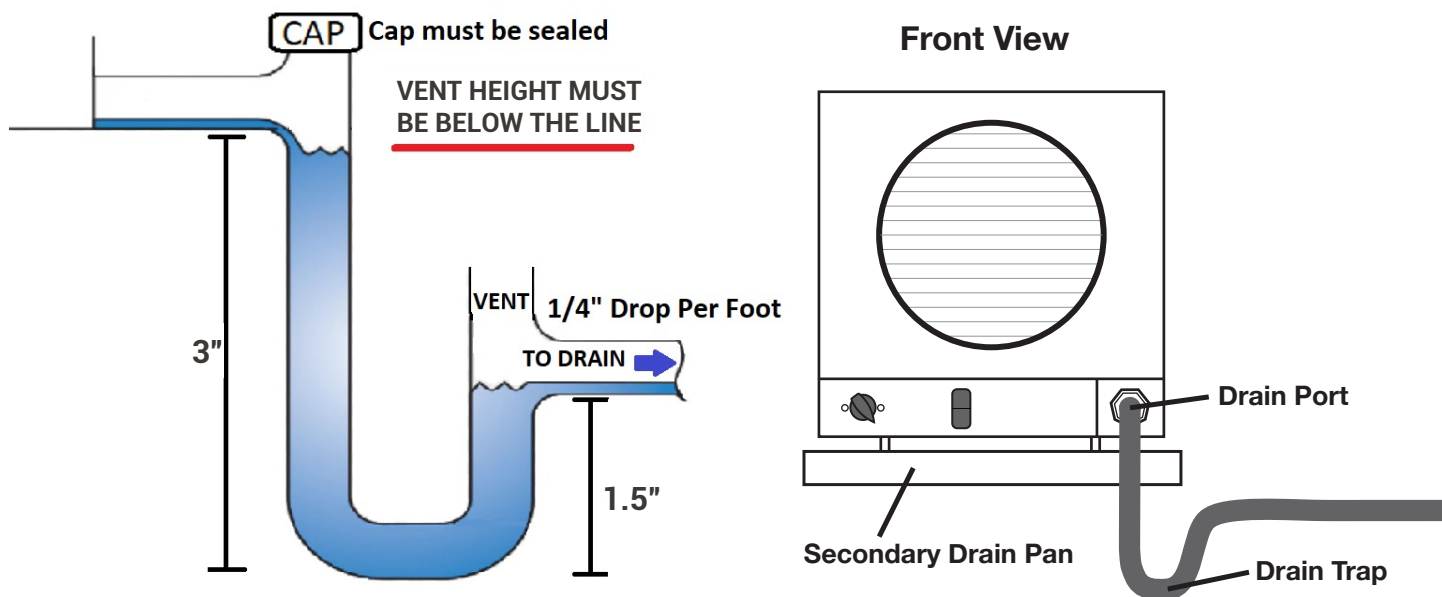



⚠ CAUTION!

DO NOT CONNECT WITH A STATIC PRESSURE GREATER THAN OR EQUAL TO +0.5 WG. CONTACT TECHNICAL SUPPORT AT (800) 533-7533 FOR ADDITIONAL DETAILS.

Ducting Considerations:

- All flexible ducting connected to the Santa-Fe Ultra70 should be UL listed.
- A short piece of flexible ducting on all Santa-Fe Ultra70 duct connections is recommended to reduce noise and vibration transmitted to rigid ductwork in the structure.
- Use a minimum 8" diameter round or equivalent rectangular duct for total duct lengths of up to 25'. Use a minimum 10" diameter or equivalent for longer lengths.
- Grills or diffusers on the duct ends must not excessively restrict airflow.
- A length of 8" or more of insulated flex duct or any other vibration isolating material on the outlet of the Santa-Fe Ultra70 will reduce air noise from the blower.
- Effective dehumidification may require that ducting be branched to isolated, stagnant air flow areas. When ducting to two or three areas, use 6" or larger diameter branch ducting. When ducting to four or more areas, use 4" - 6" or larger diameter branch ducting. Provisions must be made to provide airflow from supply locations to the central return location. Proper air distribution is important to ensure even humidity control and heat distribution throughout the structure.
- DO NOT locate the return in a bathroom or a kitchen.

Decide Where To Place The Unit.

⚠ CAUTION! ALLOW FOR ENOUGH SPACING TO PROPERLY ROUTE YOUR RETURN AND SUPPLY CONNECTION

Choose Weather To Place On Floor Or Hang Dehumidifier.

⚠ CAUTION! INTERNAL STOPS LIMIT FEET HEIGHT. DO NOT TIGHTEN FEET BEYOND THE RESISTANCE PROVIDED BY STOPS.

- a. **If You Place On Floor**
Attach leveling feet and use vibration pads and/or risers.

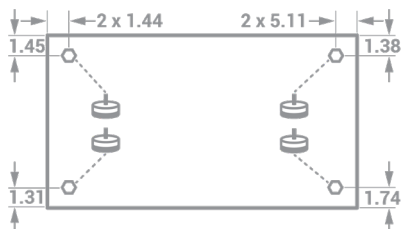

- b. **If You Hang Dehumidifier**
Use 2 Brackets* Per Unit.

* Brackets sold separately.



* NOTE: LEVELING FEET HOLD BRACKET IN PLACE

Example Of Hanging Option:

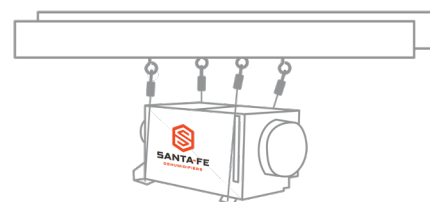



1. Recommended HVAC System Installations

a. Attic

The recommended installation draws air from a central location through a dedicated return to the dehumidifier and ducts the supply of the dehumidifier to the air supply of the HVAC system. Utilize the optional outdoor air ventilation duct to provide outdoor air.

- Install a dedicated 8" air return for the Santa-Fe Ultra70 from a central area of the structure.
- Duct the supply of the Santa-Fe Ultra70 to the supply of the HVAC system with a backdraft damper.
- If the existing system has multiple returns, instead of installing a dedicated return to the Santa-Fe Ultra70, it is possible to select one to disconnect from the existing HVAC system and use it for the dedicated Santa-Fe Ultra70 return. Select a return from a central location in the house that is always open to the rest of the structure. **DO NOT** use a return from a room where doors are kept closed.
- **DO NOT** locate return in a bathroom or kitchen.
- Control should be located remotely from the dehumidifier and placed in a central location.

Dedicated Santa-Fe Return to HVAC Supply

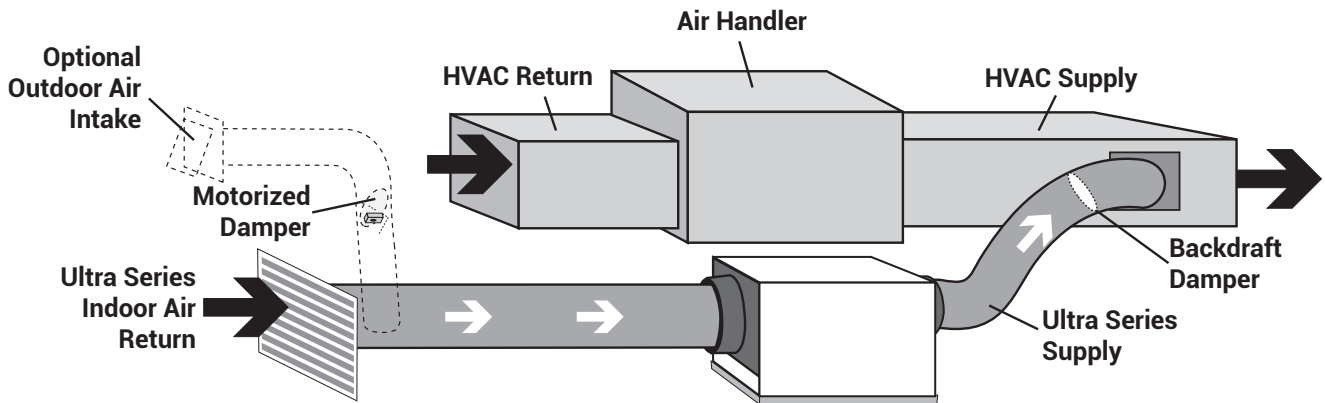



b. Installation in a Basement or Crawlpace

Install a separate 8" return for the Ultra70 in a central area of the structure. Duct the supply of the dehumidifier to the air supply of the HVAC system with a backdraft damper.

Optional: Duct the supply of the Ultra70 to a 8" x 8" x 8" tee/damper with a gravity draft damper, adjusted to 20% open to the basement. **CAUTION:** Air takes the path of least resistance. If the upper levels of the living space are not receiving the appropriate amount of dry air, this damper may need to be adjusted. When the dehumidifier is not running, there is a chance that air from the basement or crawlpace will make its way back through the gravity damper and into the living space.

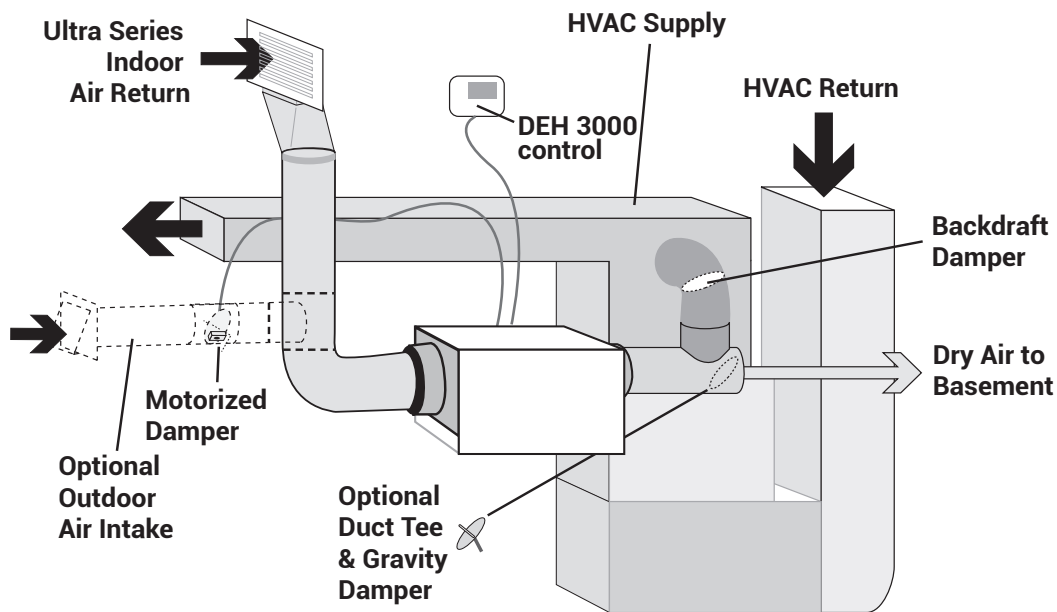



2. Alternative HVAC System Installation

If the Recommended Dedicated Ultra Series Return to HVAC Supply Installation is not possible, there are several alternative installation options available.

- DO NOT locate return in a bathroom or kitchen.
- Control should be located remotely from the dehumidifier and placed in a central location.
- For basement and crawl space installations, an optional tee can be installed on the Ultra Series Supply.

a. HVAC Return to HVAC Supply

Check Damper should be in place between the Return and Supply connections of the dehumidifier.

If Check Damper is not in place, the HVAC fan must turn on when the dehumidifier is in operation.

If the system has greater than 0.5" WG the ducting must be reconfigured.

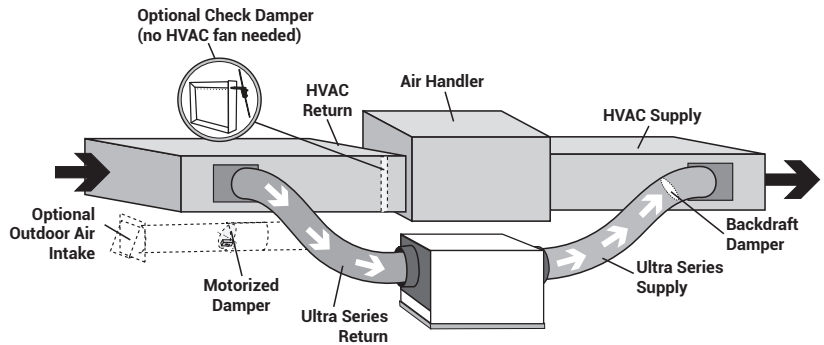

b. HVAC Supply to HVAC Supply

⚠ CAUTION!

TO AVOID THE DEHUMIDIFIER CYCLING IN AND OUT OF DEFROST, IT IS RECOMMENDED THAT THE LEAVING AIR TEMPERATURE OF THE A/C COIL IS NOT BELOW 55°F. ALSO, THIS INSTALL IS NOT RECOMMENDED FOR CLIMATES WHERE THE HEATING SYSTEM WILL RUN DURING THE SPRING AND FALL TIMES OF THE YEAR, AS THIS COULD DIMINISH THE WATER REMOVAL CAPABILITY OF THE DEHUMIDIFIER.

If Check Damper is not in place, the HVAC fan must turn on when the dehumidifier is in operation.

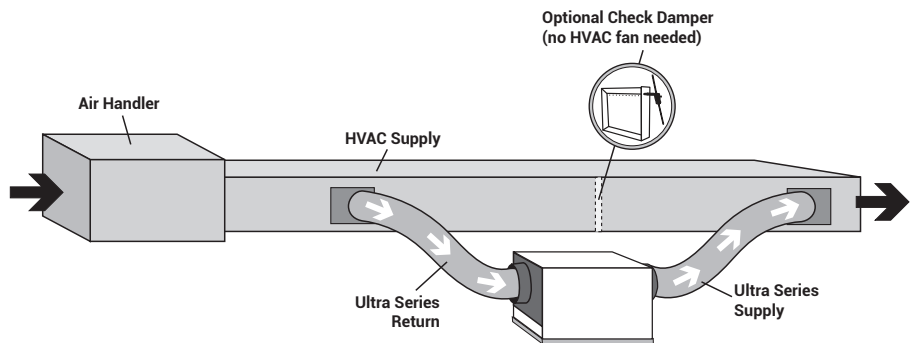

⚠ WARNING

DUE TO PRESSURE RESISTANCE IT IS NOT RECOMMENDED TO USE THE OPTIONAL OUTDOOR AIR INTAKE WHEN INSTALLING THE DEHUMIDIFIER SUPPLY TO SUPPLY.



⚠ CAUTION!

PLEASE NOTE: RETURN TO RETURN INSTALLS ARE TO BE CONSIDERED LAST RESORT OPTIONS AND ARE NOT RECOMMENDED. THE DEHUMIDIFIER WILL HEAT THE AC COOLING COILS WHICH DIMINISHES THE AMOUNT OF WATER THE AC SYSTEM WILL REMOVE WHEN OPERATING. IF THIS INSTALLATION IS CHOSEN, THE DEHUMIDIFIER MUST ACTIVATE THE HVAC BLOWER AND AC CALLS NEED TO LOCK OUT THE DEHUMIDIFIER FROM RUNNING. PLEASE CHECK YOUR LOCAL CODES PRIOR TO INSTALLING.

c. Dedicated Ultra Series Return to HVAC Return

Create a separate return for the Ultra Series Dehumidifier in a central area of the building.

Installing the supply air from the Ultra Series Dehumidifier to the return of the HVAC system requires the HVAC fan to run when the Ultra Series Dehumidifier is operating.

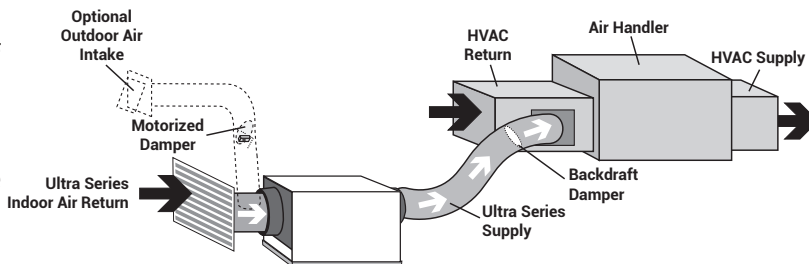

d. HVAC Return to HVAC Return

If Check Damper is not in place, the HVAC fan must turn on when the dehumidifier is in operation.

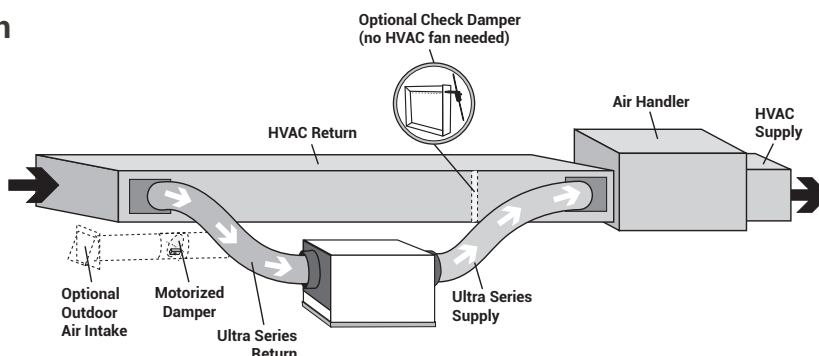

e. No Existing Ductwork Installation

When installing the Ultra Series Dehumidifier in a structure that does not have a forced-air HVAC system or is not being tied into the system, a single return for the Ultra70 should be installed in a central location.

Install a 6" insulated duct from outside, teeing into the 8" return duct of the Ultra Series Dehumidifier to provide outdoor air ventilation (optional).

The supply of the Ultra Series Dehumidifier should be ducted to the rooms in the home that have the ductless mini-split heads and as close to the heads as possible. Be sure to utilize multiple rooms to allow air inside the structure to properly circulate. Proper air distribution is important to ensure even humidity control and heat distribution throughout the structure.

A 6" diameter duct is recommended for branches to bedrooms. An 8" diameter duct is recommended for branches to larger areas.

- DO NOT locate return in a bathroom or kitchen.
- DO NOT locate the supply in rooms where doors may be closed.
- Control should be located remotely from the dehumidifier and placed in a central location.

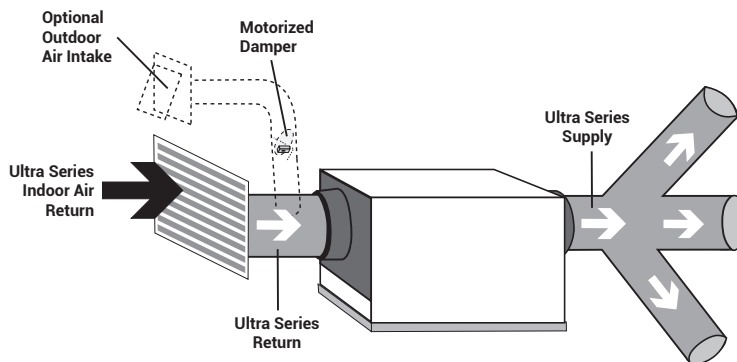



⚠️ WARNING!

WHEN INSTALLING THE DEHUMIDIFIER AS PART OF A COMBUSTION TYPE HVAC SYSTEM (GAS, OIL, PROPANE, ETC.), FOLLOW ALL LOCAL AND NATIONAL BUILDING AND SAFETY CODES.

1. Recommended Closet Installation

Due to space limitations, a closet installation may require additional considerations. Locate the dehumidifier under or next to the HVAC system as space allows. A passive vent or louver door is required to allow air to be pulled in from the living space.

- No inlet duct is required. Air is pulled through the louvers or grille from the living space.
- Control should be placed in a central location or the onboard control can be used for this installation.
- Where inlet space is restricted, the inlet duct collar is optional.
- Where outlet space is restricted, the outlet duct collar is optional or vertical flow through may be preferred.

Central Return to HVAC Supply

Duct the supply of the Ultra Series Dehumidifier to the supply of the existing HVAC system with a backdraft damper.

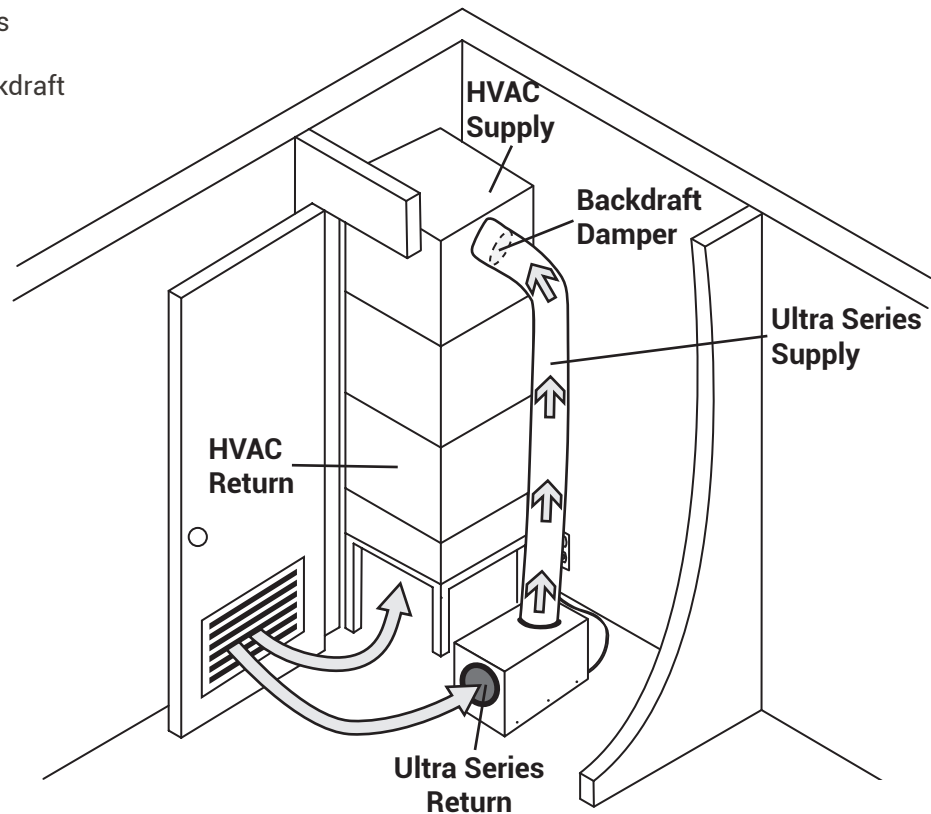



⚠ CAUTION!

PLEASE NOTE: RETURN TO RETURN INSTALLS ARE TO BE CONSIDERED LAST RESORT OPTIONS AND ARE NOT RECOMMENDED. THE DEHUMIDIFIER WILL HEAT THE AC COOLING COILS WHICH DIMINISHES THE AMOUNT OF WATER THE AC SYSTEM WILL REMOVE WHEN OPERATING. PLEASE CHECK YOUR LOCAL CODES PRIOR TO INSTALLING.

2. Alternative Closet Installation

If the Recommended Closet Installation is not possible, there are alternative installation options available.

- No inlet duct is required. Air is pulled through the louvers or grille from the living space.
- Control should be placed in a central location or the onboard control can be used for this installation.

a. Central Return to HVAC Return

Duct the supply of the Ultra Series Dehumidifier to the return side of the existing HVAC system.

In a central return system, the HVAC fan must run when the dehumidifier is running.

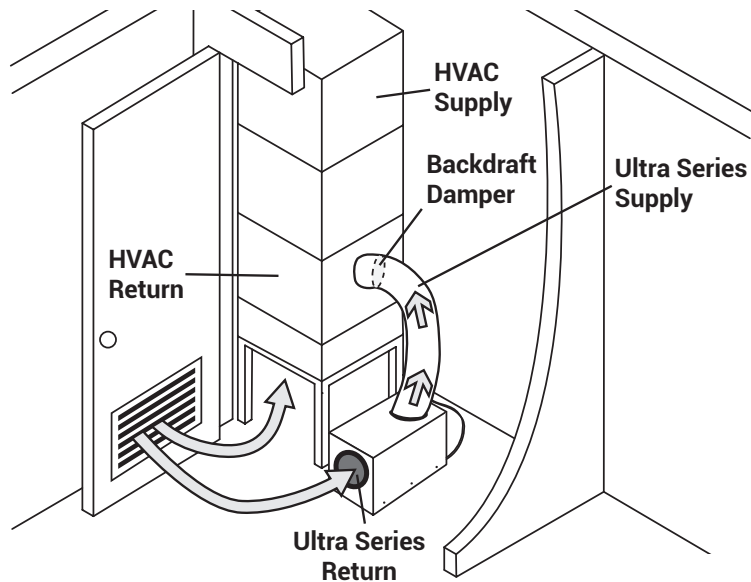



Outdoor air ventilation is optional.

Outdoor air may be brought into the structure by connecting an insulated duct from outside the structure to a tee located in the inlet duct of the Santa-Fe Ultra70. A ventilation control is needed to program the time and frequency that the unit introduces outside air. The time and frequency of ventilation should be based on the size and occupancy of the residence.

- The 6" outdoor air ventilation duct should tee into the 8" round collar on the front of the Santa-Fe Ultra70.
- An insulated 6" diameter duct can provide up to 55 CFM of outside air.
- Performance of the Santa-Fe Ultra70 can be impacted by inside and outside air conditions.
- When a 6" motorized damper is used, a digital control is required.
- It may be necessary to use 8" duct work if additional outdoor air is required.
- In cold climates or at times when the dew point is low, ventilation can be used to dehumidify the structure, making the Santa-Fe Ultra70 capable of year-round drying.

Outdoor Air Ventilation With Dehumidifier Off and Fan Only Operation

Outside air mixes with return air prior to beginning the dehumidification process. Outside and inside temperature and relative humidity will impact the combined outlet air conditions.

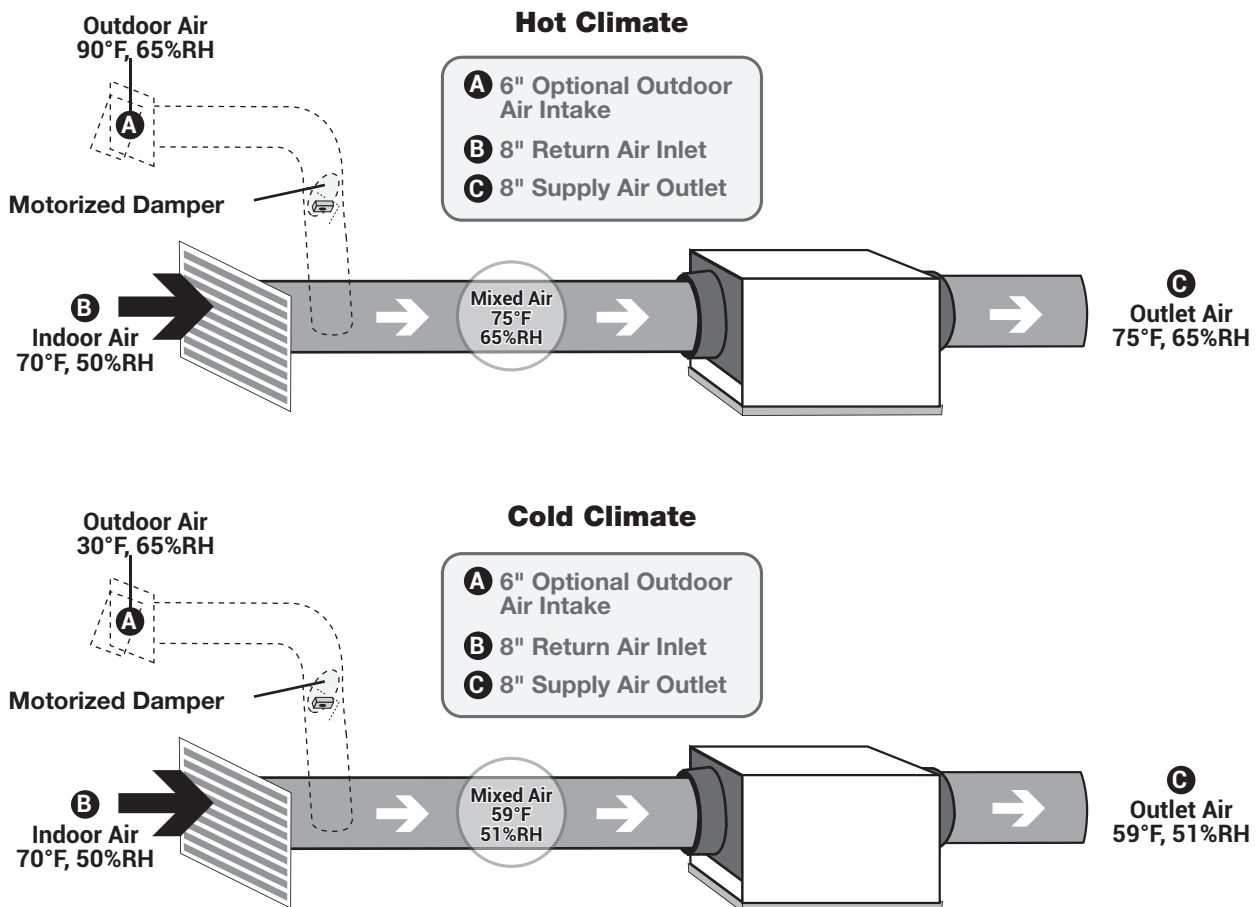



Determine Ventilation Requirements

The MINIMUM ventilation requirement is calculated using ASHRAE 62.2-2016. Use one or both of the options below to determine your ventilation requirement. Follow all local and national building and safety codes.

Option 1: Calculating Airflow Requirement Using ASHRAE 62.2-2016 Airflow Equation

ASHRAE Airflow in CFM = [House Area in Sq.Ft. x 0.03] + [(Number of Bedrooms + 1) x 7.5]

NOTE: Use 'Number of Bedrooms + 1' or 'Number of Occupants', whichever is larger.

Example 1: Number of Bedrooms + 1

1800 square foot house with 3 bedrooms, 4 occupants = [1800 X 0.03] + [(3+1) X 7.5] = 84 CFM

Example 2: Number of Occupants

1800 square foot house with 3 bedrooms, 5 occupants = [1800 X 0.03] + [5 X 7.5] = 91.5 CFM

Record the required CFM _____

Option 2: Calculating Airflow Requirement Using Table 4.1 from ASHRAE 62.2-2019

Ventilation Air Requirements, CFM

Floor Area (ft ²)	Number of Bedrooms				
	1	2	3	4	5
<500	30	38	45	53	60
501-1000	45	56	60	68	75
1001-1500	60	68	75	83	90
1501-2000	75	83	90	98	105
2001-2500	90	98	105	113	120
2501-3000	105	113	120	128	135
3001-3500	120	128	135	143	150
3501-4000	135	143	150	158	165
4001-4500	150	158	165	173	180
4501-5000	165	173	180	188	195

Table 4.1 from ASHRAE 62.2-2019

Record the required CFM _____



The Santa-Fe Ultra70 features a built-in dehumidistat control as well as the ability to wire a separate remote mounted control to the unit.

If using the built-in dehumidistat to control the unit, locate the unit in an location where it can accurately sense the humidity of the area where humidity control is desired. Adjust the humidity control so that the unit maintains the desired level of humidity.

If the Santa-Fe Ultra70 is located outside of the area where humidity control is desired, consider using a remote wired humidity controller that is located in the area where humidity control is desired. In this configuration the built in dehumidastat should be set to off. Santa-Fe offers the DEH 3000 proprietary remote mounted control. The DEH 3000 monitors and controls relative humidity and proper ventilation levels in their home. This control is also available in a version that has remote sensing capability called the DEH 3000R.

NOTE: The DEH 3000 is sold separately. Other thermostats are compatible with the Santa-Fe Ultra70.

Wiring Controls

CAUTION!

DO NOT ALLOW THE 24V TERMINAL FROM THE SANTA-FE ULTRA70 TO CONTACT THE COM TERMINAL ON THE SANTA-FE ULTRA70 OR DAMAGE TO THE TRANSFORMERS WILL RESULT.

a. Circuit Breaker

To prevent damage to the 24 volt control transformer, the Santa-Fe Ultra70 comes with a resettable circuit breaker. Check wiring for any electrical short and repair before resetting breaker. Resetting the circuit breaker without correcting the electrical short may result in transformer damage. Be sure to check the electrical schematic in this manual or inside the access panel of the Santa-Fe Ultra70 before making any control connections. The reset button for the circuit breaker can be found on the back of the unit.

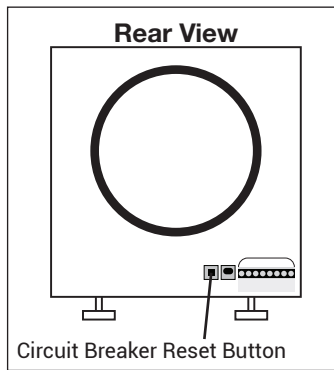

b. Control Connections

The control and the Santa-Fe Ultra70 are labeled to prevent confusion. Depending on the control, some of the screw terminals on the Santa-Fe Ultra70 may not be used. Be sure to consult the electrical schematic in this manual or inside the access panel of the Santa-Fe Ultra70 before making control connections.





A low voltage control must be used with the Santa-Fe Ultra70.

Terminal Block Control Operation

COM	24VAC Power Transformer Neutral Side
FAN	Fan Control
24V	Transformer High Side
DEHU	Dehumidification (Fan and Compressor) Control
Float	External Low Voltage Float Switch or Water Sensor (Use Normally Closed Switch)
Float	External Low Voltage Float Switch or Water Sensor (Use Normally Closed Switch)

Between the COM lead and the 24V TERMINAL is a 40VA transformer. This low voltage power source powers the relay coils which control the fan and compressors. This 24VAC transformer can also be used to power HVAC accessories external to the dehumidifier.

Compressor ON/Fan On	Make contact between 24V and DEHU terminals
Compressor OFF/Fan On	Make contact between 24V and FAN terminals
Power HVAC Accessory	Connect the accessory to the COM and 24V terminals

NOTE: 18 gauge wire needed between the Santa-Fe Ultra70 dehumidifier and the external control.



The Santa-Fe Ultra70 is equipped with a MERV-13 (Dimensions: 0.75" x 9.00" x 11.38") air filter. The filter should be checked and replaced every three to six months. Operating the unit with a dirty filter will reduce dehumidifier capacity and efficiency.

DO NOT operate the unit without the recommended filter. Filter non-compliance voids the product warranty.

CAUTION!

MAKE SURE UNIT IS OFF BEFORE CHANGING THE FILTER.

Changing the Filter

For greatest filtration and efficiency of the Santa-Fe Ultra70, it is recommended the air filter be replaced every three to six months with a MERV-13 rated filter.

Step 1: Remove the filter door from one side of the Santa-Fe Ultra70 by pushing the snap button in and gently pulling the door away from the unit. Then pull up to disengage the door from the slot.

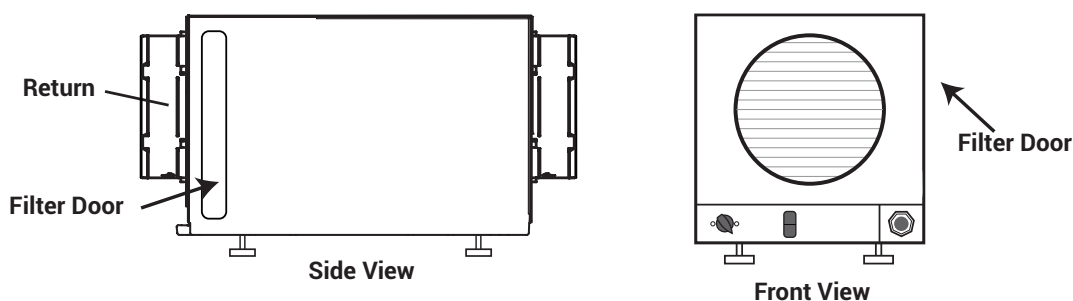

Step 2: Remove the filter by gently pulling straight out of the unit. Insert new filter by gently pushing it straight into the unit. Make sure the AIR FLOW arrow on the filter is pointing into the unit.

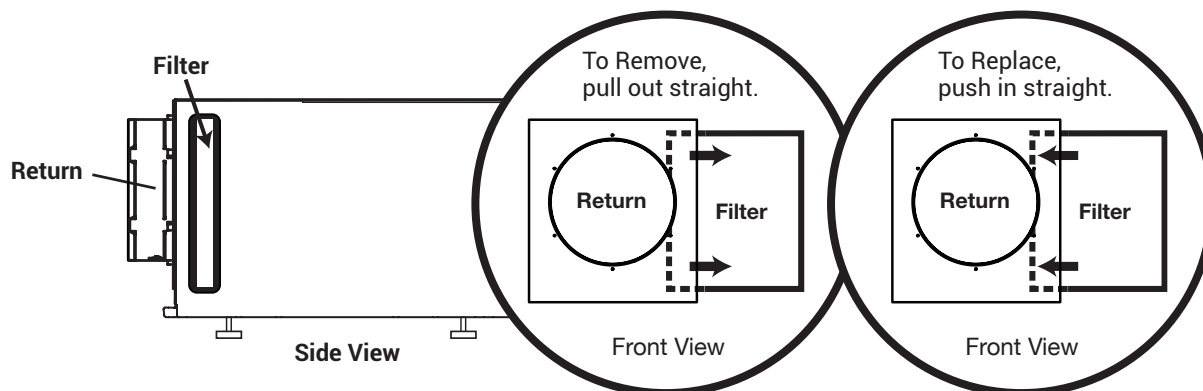

Step 3: Replace filter door ensuring the opening is fully covered.

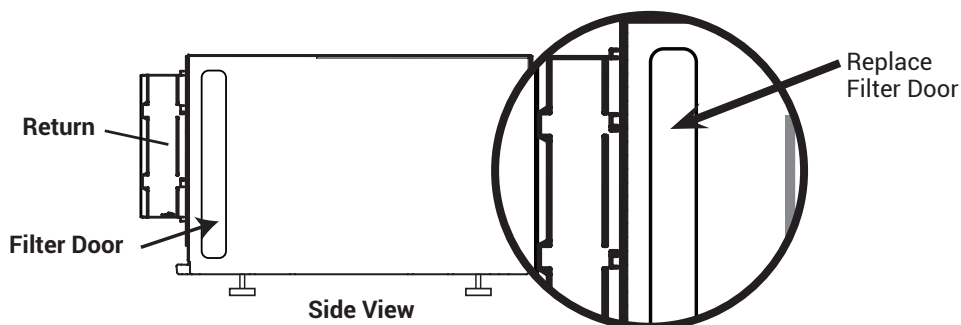



MERV Rating Chart

Standard 52.5 Minimum Efficiency Reporting Value	Dust Spot Efficiency	Arrestance	Typical Controlled Contaminant	Typical Applications and Limitations	Typical Air Filter/Cleaner Type
20	n/a	n/a	< 0.30 pm Particle Size	Cleanrooms	≥99.999% eff. On 10-20 pm Particles
19	n/a	n/a	Virus (unattached)	Radioactive Materials	Particles
18	n/a	n/a	Carbon Dust	Pharmaceutical Man.	Particulates
17	n/a	n/a	All Combustion Smoke	Carcinogenic Materials	≥99.97% eff. On 30 pm Particles
16	n/a	n/a	0.30-1.0 pm Particle Size	General Surgery	Bag Filter - Nonsupported
15	>95%	n/a	All Bacteria	Hospital Inpatient Care	Micro Fine Fiberglass or Synthetic media, 12-36 in. Deep, 6-12 Pockets
14	90-95%	>98%	Most Tobacco Smoke	Smoking Lounges	Box Filter - Rigid Style Cartridge
13	89-90%	>98%	Proplet Nuceli (Sneeze)	Superior Commercial Buildings	Filters 6 to 12 in. Deep, May Use Lofted or Paper Media
12	70-75%	>95%	1.0-3.0 pm Particle Size Legionella	Superior Residential	Bag Filter - Nonsupported
11	60-65%	>95%	Humidifier Dust Lead Dust	Better Commercial Buildings	Micro Fine Fiberglass or Synthetic media, 12-36 in. Deep, 6-12 Pockets
10	50-55%	>95%	Milled Flour		Box Filter - Rigid Style Cartridge
9	40-45%	>90%	Welding Fumes	Hospital Laboratories	Filters 6 to 12 in. Deep, May Use Lofted or Paper Media
8	30-35%	>90%	3.0-10.0 pm Particle Size	Commercial Buildings	Pleated Filters - Disposable, Extended Surface Area, Thick with Cotton-Polyester Blend Media, Cardboard Frame
7	25-30%	>90%	Mold Spores Hair Spray	Better Residential	Cartridge Filters - Graded Density Viscous Coated Cube or Pocket Filters, Synthetic Media
6	<20%	85-90%	Fabric Protector Dusting Aids		Throwaway - Disposable Synthetic Panel Filter
5	<20%	80-85%	Cement Dust Pudding Mix	Paint Booth Inlet	
4	<20%	75-80%	>10.0 pm Particle Size Pollen	Minimal Filtration	Throwaway - Disposable Synthetic Panel Filter
3	<20%	70-75%	Dust Mites Standing Dust	Residential	Washable - Aluminum Mesh
2	<20%	65-70%	Spray Paint Dust		
1	<20%	<65%	Textile Fibers Carpet Fibers	Window A/C Units	Electrostatic - Self Charging Woven Panel Filter

Table Data Source: United States Environmental Protection Agency



WARNING!

SERVICING THE DEHUMIDIFIER WITH ITS HIGH PRESSURE REFRIGERANT SYSTEM AND HIGH VOLTAGE CIRCUITRY PRESENTS A HEALTH HAZARD WHICH COULD RESULT IN DEATH, SERIOUS BODILY INJURY, AND/OR PROPERTY DAMAGE. ONLY QUALIFIED SERVICE PEOPLE SHOULD SERVICE THIS UNIT.

Warranty

A warranty certificate has been enclosed in this manual; read it before any repair is initiated. If a warranty repair is required, call the factory first at 1-800-334-6011 for warranty claim authorization and technical assistance.

Technical Description

The dehumidifier uses a refrigeration system similar to an air conditioner's to remove heat and moisture from incoming air, and add heat to the air that is discharged.

Hot, high-pressure refrigerant gas is routed from the compressor to the condenser coil. The refrigerant is cooled and condensed by giving up its heat to the air that is about to be discharged from the unit. The refrigerant liquid then passes through a filter/drier and expansion device which causes the refrigerant pressure and temperature to drop. It next enters the evaporator coil where it absorbs heat from the incoming air and evaporates. The evaporator operates in a flooded condition, which means that all the evaporator tubes contain liquid refrigerant during normal operation. A flooded evaporator should maintain nearly constant pressure and temperature across the entire coil, from inlet to outlet.

The compressor collects the cool refrigerant gas and compresses it to a high pressure and temperature to repeat the process.

Service Personnel

Only qualified HVAC or electrical contractors are allowed to conduct maintenance, service and/or repair operations on the dehumidifier. Examples include but are not limited to breaking into the refrigerating circuit, opening of sealed components, and/or opening of ventilated enclosures.

- Prior to beginning work on the dehumidifier, safety checks are necessary to ensure that the risk of ignition is minimized.
- For repair to the REFRIGERATING SYSTEM, a qualified contractor should first establish a controlled procedure so as to minimize the risk of a flammable gas or vapor being present while the work is being performed
- All maintenance staff and others working in the local area shall be instructed on the nature of work being carried out. Work in confined spaces shall be avoided.
- The area shall be checked with an appropriate refrigerant detector prior to and during work, to ensure the technician is aware of potentially toxic or flammable atmospheres. Ensure that the leak detection equipment being used is suitable for use with all applicable refrigerants, i.e. non-sparking, adequately sealed or intrinsically safe.
- If any hot work is to be conducted on the refrigerating equipment or any associated parts, appropriate fire extinguishing equipment shall be available to hand. Have a dry powder or CO2 fire extinguisher adjacent to the charging area.
- No person carrying out work in relation to a REFRIGERATING SYSTEM which involves exposing any pipe work shall use any sources of ignition in such a manner that it may lead to the risk of fire or explosion. All possible ignition sources, including cigarette smoking, should be kept sufficiently far away from the site of installation, repairing, removing and disposal, during which refrigerant can possibly be released to the surrounding space. Prior to work taking place, the area around the equipment is to be surveyed to make sure that there are no flammable hazards or ignition risks. "No Smoking" signs shall be displayed.
- Ensure that the area is in the open or that it is adequately ventilated before breaking into the system or conducting any hot work. A degree of ventilation shall continue during the period that the work is carried out. The ventilation should safely disperse any released refrigerant and preferably expel it externally into the atmosphere.



The following checks shall be applied to installations using FLAMMABLE REFRIGERANTS:

- Where electrical components are being changed, they shall be fit for the purpose and to the correct specification. At all times Santa-Fe's maintenance and service guidelines shall be followed. If in doubt, consult Santa-Fe's technical department for assistance.
- The actual REFRIGERANT CHARGE is in accordance with the room size within which the refrigerant containing parts are installed;
- The ventilation machinery and outlets are operating adequately and are not obstructed;
- Marking to the equipment continues to be visible and legible. Markings and signs that are illegible shall be corrected;
- Dehumidifiers are installed in a position where they are unlikely to be exposed to any substance which may corrode refrigerant containing components, unless the components are constructed of materials which are inherently resistant to being corroded or are suitably protected against being so corroded.

Checks to Electrical Devices

Repair and maintenance to electrical components shall include initial safety checks and component inspection procedures. If a fault exists that could compromise safety, then no electrical supply shall be connected to the circuit until it is satisfactorily dealt with. If the fault cannot be corrected immediately but it is necessary to continue operation, an adequate temporary solution shall be used. This shall be reported to the owner of the equipment so all parties are advised.

Initial safety checks shall include:

- that capacitors are discharged: this shall be done in a safe manner to avoid possibility of sparking;
- that no live electrical components and wiring are exposed while charging, recovering or purging the system;
- that there is continuity of earth bonding;

Sealed Electrical Components Shall Be Replaced

- During repairs to sealed components, all electrical supplies shall be disconnected from the equipment being worked upon prior to any removal of sealed covers, etc. If it is absolutely necessary to have an electrical supply to equipment during servicing, then a permanently operating form of leak detection shall be located at the most critical point to warn of a potentially hazardous situation.
- Particular attention shall be paid to the following to ensure that by working on electrical components, the casing is not altered in such a way that the level of protection is affected. This shall include damage to cables, excessive number of connections, terminals not made to original specification, damage to seals, incorrect fitting of glands, etc.
- Ensure that the equipment is mounted securely.
- Ensure that seals or sealing materials have not degraded to the point that they no longer serve the purpose of preventing the ingress of flammable atmospheres.
- Replacement parts shall be in accordance with Santa-Fe specifications.

Intrinsically Safe Components Must Be Replaced

- Do not apply any permanent inductive or capacitance loads to the circuit without ensuring that this will not exceed the permissible voltage and current permitted for the equipment in use.
- Intrinsically safe components are the only types that can be worked on while live in the presence of a flammable atmosphere. The test apparatus shall be at the correct rating.
- Replace components only with parts specified by Santa-Fe. Other parts may result in the ignition of refrigerant in the atmosphere from a leak.

NOTE: The use of silicon sealant can inhibit the effectiveness of some types of leak detection equipment. Intrinsically safe components do not have to be isolated prior to working on them.

Check that cabling will not be subject to wear, corrosion, excessive pressure, vibration, sharp edges or any other adverse environmental effects. The check shall also take into account the effects of aging or continual vibration from sources such as compressors or fans.



Detection of Flammable Refrigerants

Under no circumstances shall potential sources of ignition be used in the searching for or detection of refrigerant leaks. A halide torch (or any other detector using a naked flame) shall not be used.

The following leak detection methods are deemed acceptable for all refrigerant systems:

- Electronic leak detectors may be used to detect refrigerant leaks but, in the case of FLAMMABLE REFRIGERANTS, the sensitivity may not be adequate, or may need re-calibration. (Detection equipment shall be calibrated in a refrigerant-free area.) Ensure that the detector is not a potential source of ignition and is suitable for the refrigerant used. Leak detection equipment shall be set at 25% LFL of the refrigerant and shall be calibrated to 454B.
- Leak detection fluids are also suitable for use with most refrigerants but the use of detergents containing chlorine shall be avoided as the chlorine may react with the refrigerant and corrode the copper pipe.

NOTE: Examples of leak detection fluids are:

- bubble method
- fluorescent method agents.
- If a leak is suspected, all open flames shall be removed/extinguished.

If a leakage of refrigerant is found which requires brazing, all of the refrigerant shall be recovered from the system, or isolated (by means of shut off valves) in a part of the system remote from the leak. Removal of refrigerant shall be according to Clause DD.9 of 60335-2-40.

Refrigerant Removal and Evacuation

When breaking into the refrigerant circuit to make repairs – or for any other purpose – conventional procedures shall be used. However, for FLAMMABLE REFRIGERANTS it is important that best practice is followed since flammability is a consideration. The following procedure shall be adhered to:

- Safely remove refrigerant following local and national regulations.
- The REFRIGERANT CHARGE shall be recovered into the correct recovery cylinders if venting is not allowed by local and national codes.
- For appliances containing flammable refrigerants, the system shall be purged with oxygen-free nitrogen to render the appliance safe for flammable refrigerants.
- This process might need to be repeated several times. Compressed air or oxygen shall not be used for purging refrigerant systems.
- When the final oxygen-free nitrogen charge is used, the system shall be vented down to atmospheric pressure to enable work to take place.
- Open the circuit by cutting or brazing.
- Ensure that the outlet for the vacuum pump is not close to any POTENTIAL IGNITION SOURCES and that ventilation is available.

Charging Procedures

In addition to conventional charging procedures, the following requirements shall be followed:

- Ensure that contamination of different refrigerants does not occur when using charging equipment. Hoses or lines shall be as short as possible to minimize the amount of refrigerant contained in them.
- Cylinders shall be kept in an appropriate position according to the instructions.
- Ensure that the REFRIGERATING SYSTEM is grounded prior to charging the system with refrigerant.
- Label the system when charging is complete (if not already).
- Extreme care shall be taken not to overfill the REFRIGERATING SYSTEM.
- Prior to recharging the system, it shall be pressure-tested with the appropriate purging gas. The system shall be leak-tested on completion of charging but prior to commissioning. A follow up leak test shall be carried out prior to leaving the site.



Decommissioning

Before carrying out this procedure, it is essential that the technician is completely familiar with the equipment and all its details. It is recommended good practice that all refrigerants are recovered safely. Prior to the task being carried out, an oil and refrigerant sample shall be taken in case analysis is required prior to re-use of recovered refrigerant. It is essential that electrical power is available before the task commences.

- Become familiar with the equipment and its operation.
- Isolate system electrically.

Before attempting the procedure, ensure that:

- mechanical handling equipment is available, if required, for handling refrigerant cylinders;
 - all personal protective equipment is available and being used correctly;
 - the recovery process is supervised at all times by a competent person;
 - recovery equipment and cylinders conform to the appropriate standards.
- Pump down refrigerant system, if possible.
 - If a vacuum is not possible, make a manifold so that refrigerant can be removed from various parts of the system.
 - Make sure that cylinder is situated on the scales before recovery takes place.
 - Start the recovery machine and operate in accordance with instructions.
 - Do not overfill cylinders (no more than 80 % volume liquid charge).
 - Do not exceed the maximum working pressure of the cylinder, even temporarily.
 - When the cylinders have been filled correctly and the process completed, make sure that the cylinders and the equipment are removed from site promptly and all isolation valves on the equipment are closed off.
 - Recovered refrigerant shall not be charged into another REFRIGERATING SYSTEM unless it has been cleaned and checked.

Labelling Decommission Machines

Equipment shall be labelled stating that it has been de-commissioned and emptied of refrigerant. The label shall be dated and signed. For appliances containing FLAMMABLE REFRIGERANTS, ensure that there are labels on the equipment stating the equipment contains FLAMMABLE REFRIGERANT.

Refrigerant Recovery

- When removing refrigerant from a system, either for servicing or decommissioning, it is recommended good practice that all refrigerants are removed safely.
- When transferring refrigerant into cylinders, ensure that only appropriate refrigerant recovery cylinders are employed. Ensure that the correct number of cylinders for holding the total system charge is available. All cylinders to be used are designated for the recovered refrigerant and labelled for that refrigerant (i.e. special cylinders for the recovery of refrigerant). Cylinders shall be complete with pressure-relief valve and associated shut-off valves in good working order. Empty recovery cylinders are evacuated and, if possible, cooled before recovery occurs.
- The recovery equipment shall be in good working order with a set of instructions concerning the equipment that is at hand and shall be suitable for the recovery of all appropriate refrigerants including, when applicable, FLAMMABLE REFRIGERANTS. In addition, a set of calibrated weighing scales shall be available and in good working order. Hoses shall be complete with leak-free disconnect couplings and in good condition. Before using the recovery machine, check that it is in satisfactory working order, has been properly maintained and that any associated electrical components are sealed to prevent ignition in the event of a refrigerant release. Consult manufacturer if in doubt.
- The recovered refrigerant shall be returned to the refrigerant supplier in the correct recovery cylinder, and the relevant waste transfer note arranged. Do not mix refrigerants in recovery units and especially not in cylinders.
- If compressors or compressor oils are to be removed, ensure that they have been evacuated to an acceptable level to make certain that FLAMMABLE REFRIGERANT does not remain within the lubricant. The evacuation process shall be carried out prior to returning the compressor to the suppliers. Only electric heating to the compressor body shall be employed to accelerate this process. When oil is drained from a system, it shall be carried out safely.



Troubleshooting

CAUTION!

TROUBLESHOOTING SHOULD BE PERFORMED BY A QUALIFIED HVAC TECHNICIAN.

Symptom	Possible Reason	Troubleshooting Procedure
Neither fan nor compressor running. Dehumidification is being called for.	<ol style="list-style-type: none"> 1. Dehumidifier unplugged or no power to outlet. 2. Humidity control set too high. 3. Loose connection in internal or control wiring. 4. Defective compressor relay. 5. Defective control transformer. 	<p> WARNING! ELECTRICAL SHOCK HAZARD: Electrical power must be present to perform some tests. These tests should be performed by a qualified service person. Troubleshooting Procedure for Control Related Issues This method of diagnosis will test the 3 main components of the control circuit individually to indicate any potential problems. This is to be used when the control will not activate the main unit.</p> <ol style="list-style-type: none"> 1. Detach field control wiring connections from the terminals on the main unit. 2. Connect the 24V and FAN terminals together; only the fan should run. Disconnect the terminals. 3. Connect the 24V and DEHU terminals together; fan and compressor should run. Disconnect the terminals. 4. If this test works, the main unit is working correctly from a control standpoint. 5. Reconnect field control wiring to the terminals on the main unit. 6. Remove the control panel cover and detach the field wiring from the control connections. 7. Connect the 24V and FAN terminals together; only the fan should run. Disconnect the terminals. 8. Connect the 24V and DEHU terminals together; fan and compressor should run. Disconnect the terminals. 9. If this test works, then the field control wiring is ok. 10. If the problem persists, then the control is most likely faulty.
Compressor is not running. Dehumidification is being called for. Fan is running.	<ol style="list-style-type: none"> 1. Defective compressor run capacitor. 2. Loose connection in compressor circuit. 3. Defective compressor overload. 4. Defective compressor. 5. Defrost thermostat open. 	
Compressor cycles on and off. Dehumidification is being called for.	<ol style="list-style-type: none"> 1. Low ambient temperature and/or humidity causing unit to cycle through defrost mode. 2. Defective compressor overload. 3. Defective compressor. 4. Defrost thermostat defective. 5. Dirty air filter(s) or air flow restricted. 6. Defective fan or relay. 	
Fan is not running. Dehumidification or fan is being called for.	<ol style="list-style-type: none"> 1. Loose connection in fan circuit. 2. Obstruction prevents fan impeller rotation. 3. Defective fan. 4. Defective fan relay. 	



Troubleshooting (Continued)

Symptom	Possible Reason	Troubleshooting Procedure
Low dehumidification capacity (evaporator is frosted continuously). Dehumidification is being called for.	<ol style="list-style-type: none"> 1. Defrost thermostat loose or defective. 2. Low refrigerant charge. 3. Dirty air filter(s) or air flow restricted. 4. Excessively restrictive ducting connected to unit. 	<p>WARNING! ELECTRICAL SHOCK HAZARD: Electrical power must be present to perform some tests. These tests should be performed by a qualified service person. Troubleshooting Procedure for Control Related Issues This method of diagnosis is used to function check the internal components in the dehumidifier. This is to be used when a performance issue is suspected.</p> <ol style="list-style-type: none"> 1. Set the humidity controller all the way to the most humid setting or off position – Did the unit shut off? 2. If yes, turn the fan setting to the ON position – does the fan start? 3. If fan starts, leave in the fan ON position and set the humidity all the way to driest setting. May have to wait 5 minutes for the compressor to start. 4. Listen for a distinct buzzing/humming sound of a compressor starting up – do you hear this noise? 5. If compressor is running and continues to run, after about 15 minutes you should feel a slight increase in air temperature being discharged out of the discharge air side of the unit. 6. If so, depending on your environmental conditions (temp/Rh%), you should see some water production out of the hose within 30 minutes or so. (Note: If the room temperature is 55 degrees or below and/or in area of low relative humidity, the dehumidifier will produce little to no water.) 7. Collecting the water removed in a 24 hour period will give a measurement of performance.
No ventilation. Ventilation is being called for.	<ol style="list-style-type: none"> 1. Loose connection in ventilation control circuit. 2. Loose connection in damper power circuit. 3. Defective outdoor air damper. 	
Dehumidifier removes some water, but not as much as expected.	<ol style="list-style-type: none"> 1. Air temperature and/or humidity have dropped. 2. Humidity meter and or thermometer used are out of calibration. 3. Unit has entered defrost cycle. 4. Dirty air filter(s) or air flow is restricted. 5. Defective defrost thermostat. 6. Low refrigerant charge. 7. Air leak such as loose cover or ducting leaks. 8. Defective compressor. 9. Restrictive ducting. 	

Refrigerant Charging

WARNING!

SERVICING THE SANTA-FE ULTRA70 WITH ITS HIGH PRESSURE REFRIGERANT SYSTEM AND HIGH VOLTAGE CIRCUITRY PRESENTS A HEALTH HAZARD WHICH COULD RESULT IN DEATH, SERIOUS BODILY INJURY, AND/OR PROPERTY DAMAGE. SERVICE MUST BE PERFORMED BY A QUALIFIED SERVICE TECHNICIAN.

If the refrigerant charge is lost due to service or a leak, the leak should be repaired and a new charge must be accurately weighed in. If any of the old charge is left in the system, it must be recovered before weighing in the new charge. Refer to the unit nameplate for the correct charge weight and refrigerant type.



Terms of Coverage

Your Santa-Fe™ Dehumidifier is expressly warranted to be free from defects in materials or workmanship for five (5) years from date of purchase and the product's components will be free of defects in workmanship or materials for a period of six (6) years following the date of purchase.

What Is Covered

The exclusive obligation of Santa-Fe under this Limited Warranty shall be, at the sole discretion of Santa-Fe, to supply, without charge, a replacement for any component or product which is found to be defective. A defective part will be replaced pursuant to this Limited Warranty with a genuine Santa-Fe part. A defective product will be replaced pursuant to this Limited Warranty with a new Santa-Fe product of equal or similar features and functionality if the original product has been discontinued or is no longer available.

Not Covered by the Limited Warranty

- Consumable or maintenance products, such as, but not limited to Air Filters.
- Products purchased from third parties that were previously used, such as previously used products purchased from eBay, similar third party/auction sites, or individuals selling used products.
- Labor charges, shipping costs, removal fees, service fees, or reinstallation costs.
- Materials furnished by the installer.
- Damage caused by misuse, abuse, improper installation, or failing to install, use, or maintain the product in accordance with the instructions provided.
- Damage to HVAC equipment caused by improper installation(s) or misapplication installation(s).
- Modifications, changes, repurposing, or alterations to the Santa-Fe product.
- Extended warranties or satisfaction guarantees offered by third parties.
- Cosmetic damage or normal wear and tear, including, but not limited to: scratches, peeling finish, or dents that do not impede the mechanical functionality of the product.
- Damage caused by acts of nature, including but not limited to: fire, collision, flood, wind, power surge, lightning strike, or mold.
- Damage caused during transit.
- Damage caused during installation due to failure to follow local, state, or federal laws, statutes, codes, or ordinances.
- Damage caused by defects in materials furnished by the installer.

Limit of Liability

IMPLIED WARRANTIES OF MERCHANTABILITY OR FITNESS FOR A PARTICULAR PURPOSE SHALL BE LIMITED IN DURATION TO THE AFOREMENTIONED EXPRESS WARRANTY PERIOD. SANTA-FE LIABILITY FOR INCIDENTAL OR CONSEQUENTIAL DAMAGES, OTHER THAN DAMAGES FOR PERSONAL INJURIES, RESULTING FROM ANY BREACH OF THE AFOREMENTIONED IMPLIED WARRANTIES OR THE ABOVE LIMITED WARRANTY IS EXPRESSLY EXCLUDED. THIS LIMITED WARRANTY IS VOID IF DEFECT(S) RESULT(S) FROM FAILURE TO INSTALL THE PRODUCT ACCORDING TO THE INSTALLATION INSTRUCTIONS. IF THE LIMITED WARRANTY IS VOID DUE TO MISAPPLICATION OR IMPROPER INSTALLATION, ALL DISCLAIMERS OF IMPLIED WARRANTIES SHALL BE EFFECTIVE UPON INSTALLATION.

If a Product or component is replaced while under warranty, the applicable limited warranty period shall not be extended beyond the original warranty time period.

Some states do not allow limitations on how long an implied warranty lasts or the exclusion or limitation of incidental or consequential damages, so the above limitation(s) may not apply to your situation. This Limited Warranty gives you specific legal rights, and you may also have other rights which vary from state to state.

WARRANTY REGISTRATION CARD

IMPORTANT WARRANTY INFORMATION - DO NOT DISCARD

REGISTER YOUR PRODUCT.

WARRANTY

WARRANTY

SERIAL
NUMBER ▶

PART
NUMBER ▶

www.santa-fe-products.com/product-registration

**Register your product using the serial
number and part number above at
www.santa-fe-products.com/product-registration**

**This is important
Warranty Information.
Please DO NOT DISCARD!**

Santa-Fe-Products.com
(888) 277-4524

