



THE **ULTRA AIRE 120V** –
 THE INDUSTRY'S ONLY
 VERTICAL DEHUMIDIFIER
 – FEATURES A SMALL
 FOOTPRINT AND OPTIONAL
 DUAL EXHAUST.

MODEL 4036400

PERFORMANCE

Water Removal	124 Pints / 15.5 Gallons
Efficiency	7.6 Pints/kWh
Energy Factor	3.6 L/kWh
Blower	445 CFM @ 0.0" WG 390 CFM @ 0.2" WG 360 CFM @ 0.4" WG
Operating Temperature	49°F Min., 95°F Max.
Sizing	Up to 3,000 Sq. Ft. / 30,000 Cu. Ft.

ELECTRICAL

Power	680 watts @ 80°F and 60% RH
Supply Voltage	115 volt – 1 phase – 60 Hz
Current Draw	5.8 amps
Power Cord	9', 115 VAC, Ground
Circuit Requirement	15 Amps



SPECIFICATIONS

Duct Connections	6" Round Inlet, 8" Round Inlet, 8" Round Outlet (x2)
Drain Connection	3/4" Threaded Female NPT
Refrigerant	R410A, 2 lbs. 5 oz.
Unit Dimensions	26.75"W x 43.5"H x 18.75"D
Unit Weight	120 lbs.

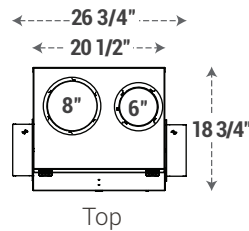

SHIPPING

Shipping Dimensions	25.25"W x 46.5"H x 22"D
Shipping Weight	145 lbs.
Pallet Quantity	1 per pallet
UPC Number	859029004663
Shipping Options	LTL

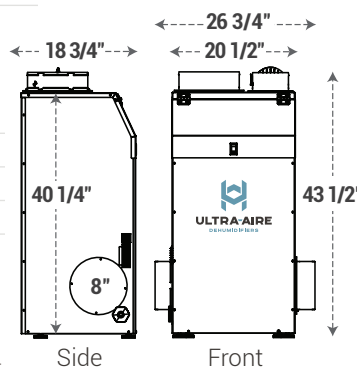

Specifications are subject to change without notice. Performance is based on pints / gallons per day @80°F/60%RH. Sizing is based on 10 foot ceiling height. Unit dimensions and weight are with collars on.

FEATURES

- + Vertical orientation for basements and mechanical rooms where floor space is limited
- + Engineered for low temperature operation providing comfort year round
- + Use of DEH 3000/R digital control for outdoor air ventilation and humidity control
- + Superior MERV-13 filtration to improve indoor air quality
- + Ducting option for fresh outdoor air ventilation
- + Push button reset for transformer protection



FILTRATION



MERV-13 FILTER

- + Designed to trap particles down to 0.3 microns
- + 90% ASHRAE Dust Spot
- + 16" x 20" x 2"

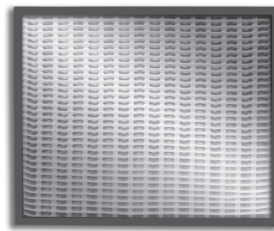

MERV-14 FILTER

- + Designed for high efficiency
- + Deep pleated 95% media filter
- + 16" x 20" x 4"

INSTALLATION



DEH 3000 DIGITAL CONTROL

- + Precise monitoring and control of moisture levels
- + Manages fresh air filtration with optional damper
- + Activates air filtration



CONDENSATE PUMP

- + For use in spaces where gravity drain is not possible
- + Includes 20-foot drain hose, giving the option to run longer distances (pump located inside the dehumidifier)
- + Pump features a float switch that directs it to run only when needed

PARTS

4035852	Compressor	4038968	Wire Harness
4034474-05	Evaporator Coil	4036967	Defrost Thermostat
4028566	Condenser Coil	4035872	Overload, Compressor
4029510	Filter / Drier	4038967	Wiring Diagram
4036164-03	Capillary Tubes	4026221	Leveling Feet
4038071	Fan (Blower)	4029894	Hose, Drain Pan
4022484	Relay, SPST	4037789	Slide Latch
4029575	Relay, DPDT	4038693	Hinge
4033032-05	Run Capacitor	4029828	Duct, Inlet, 8" Plastic
4035235-07	Fan Capacitor	4029829	Duct, Inlet, 6" Plastic With Damper
4022487	Transformer	4029588	Duct, Outlet, 8" Plastic
4036559	Circuit Breaker		
4036523	Power Cord		

PART NO.	ITEM
4039391	MERV-13 Filter
4037733	MERV-13 Filter, 4-Pack
4037734	MERV-13 Filter, 12-Pack
4022489	MERV-14 Filter

PART NO.	ITEM
4028539	DEH 3000 Digital Control
4028407	DEH 3000R Digital Control

PART NO.	ITEM
4039225	Condensate Pump

The Ultra Aire team is available Monday - Friday, 8 am - 5 pm CT.

We want to hear from you, so don't hesitate to reach out.

Need help with a warranty claim? Contact us at 800-533-7533.

Contact Customer Service at orders@thermastor.com.

SANTA-FE-PRODUCTS.COM